

# A MECHANICAL TUNER AND RF DRIVE LINE SYSTEM FOR THE ISAC II QUARTER WAVE SUPERCONDUCTING CAVITIES

K. Fong, R.E. Laxdal, A.K. Mitra, R. Poirier, T. Ries, V. Zviagantsev  
TRIUMF\*, 4004 Wesbrook Mall, Vancouver, Canada, V6T2A3

## Abstract

Stable cavity regulation at high gradient requires both a precise tuner to limit the required tuning bandwidth and a power coupler capable of operating at high forward power without a significant contribution to the static helium load. Two complimentary developments are ongoing at TRIUMF to achieve a design gradient of 6 MV/m ( $E_p = 30$  MV/m). TRIUMF is developing a mechanical tuner capable of both coarse (kHz) and fine (Hz) frequency adjustments of the cavity. The demonstrated tuner resolution is better than 0.1 micro-m (0.6 Hz) with a dynamic range of 8 KHz and a manual coarse tuning range of 33 kHz. Secondly a new rf coupling loop is being developed with the goal to operate at 200 Watts forward power with less than 1 Watt of power being added to the helium load. Mechanical details and cold test results of the ISAC-II coupling loop and mechanical tuner will be given.

## INTRODUCTION

In previous linac installations the tuning of quarter wave cavities has been accomplished with mechanical or pneumatic tuners characterized by slow response, poor resolution and/or large backlash. Detuning by microphonic noise or rapid fluctuations in helium delivery pressure are accommodated by either overcoupling to reduce the loaded Q or with a variable reactive load using a PIN diode network at the cavity. A slow tuner response affects the required Q-loading and may limit the accelerating gradient due to constraints on the stored energy.

The ISAC-II[1] medium beta cavities have a design gradient of 6 MV/m. This corresponds to a peak surface field of  $\sim 30$  MV/m and a stored energy of  $U=3.2$  J and is a significant increase over other operating heavy ion facilities. To achieve stable phase and amplitude control the natural bandwidth of  $\pm 0.1$ Hz is broadened by overcoupling to accommodate detuning by microphonic noise and helium pressure fluctuation (1 Hz/Torr). A rough rule is to use a loaded bandwidth of six times the microphonic noise plus twice the resolution of the mechanical tuner [2]. The ISAC-II medium beta cavities are outfitted with a passive mechanical damper[3] and the microphonics are not expected to be more than a few Hz RMS. The chosen tuning bandwidth of  $\pm 20$  Hz demands a cw forward power of 200 Watts and peak power capability of 400 Watts to be delivered to the coupling loop at the cavity.

Two complimentary developments are ongoing at TRI-

UMF to achieve the design goal. In the first a new rf coupling loop is being developed with the goal to operate at 200 Watts forward power with less than 1 Watt of power being added to the helium load. Secondly TRIUMF is developing a mechanical tuner capable of both coarse (kHz) and fine (Hz) frequency adjustments of the cavity. The goal for the ISAC-II cavity tuner is to achieve fine (1 Hz) tuning capability with a response time to control fast helium pressure fluctuations allowing stable operation within a bandwidth of  $\Delta f = \pm 20$  Hz.

## MECHANICAL TUNER

### Tuning Plate

The tuning plate (see Fig. 1) consists of 1 mm thick RRR Niobium sheet of 240 mm diameter fixed to the bottom Niobium flange by bolts and retaining flange. A flat plate can be used but the deflection force required is parabolic with distance and tends to assume a concave shape upon cooling leading to highly non-linear behaviour. To overcome these problems the ISAC-II tuning plate is spun with a single ‘oil-can’ convolution and milled with eight radial 1 mm slots. The plate is capable of allowing  $\pm 20$ kHz ( $\pm 3$  mm) of tuning range before yielding. Cold tests with the plate give Q and gradient values consistent with the flat plate performance[1].

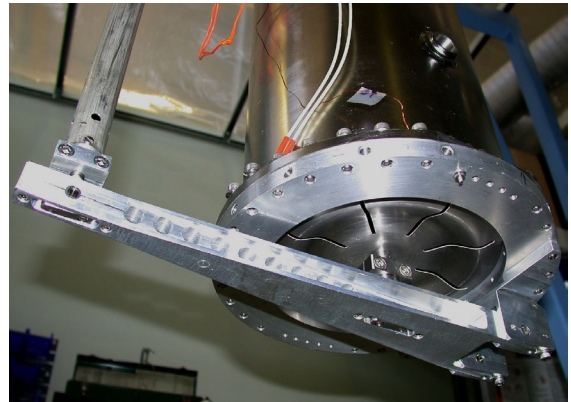

Figure 1: The tuner plate, lever arm, bottom of push-rod and cavity viewed from below.

### Tuner

The tuner diaphragm is actuated by a simple lever arm and push rod arrangement as shown in Fig. 2. The top end of the push rod goes from vacuum to air via an edge welded bellows. The push rod is coupled to a linear direct drive

\* TRIUMF receives funding via a contribution agreement through the National Research Council of Canada

ironless coil servomotor. A low stiffness coil is attached to counteract the effects of air pressure on the bellows. The spring compression is manually adjustable in order to set the mechanically self-seeking equilibrium position before servo startup. The push rod consists of a 25 mm diameter 316 stainless steel tubing with a 0.38 mm thick wall giving less than 0.1 W of heat load. The rotary joints are comprised of anti-backlash, high strength and stiffness pivot bearings.

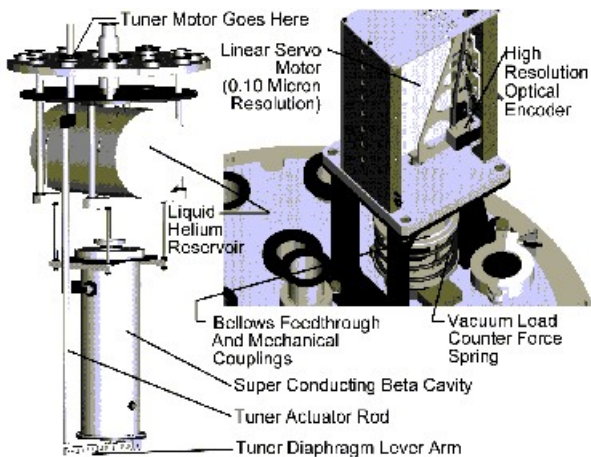

Figure 2: Tuner drive assembly layout.

## Controls

The ISAC-II rf control[4] is based on a self-excited loop with a locking circuit for amplitude and phase regulation. The tuner is fed a position signal integrated from the control loop phase error. The heart of the supervisory tuner control is the PCI bus digital servo controller. The feedback position of the motor is sent to the controller by the servo amplifier in phase quadrature form. The return command drive error signal is analog in the range  $\pm 10$  V but with the “impress” of the previous 12 bit signal.

The position of the motor is sensed by a high resolution sine encoder and fed through special subdividing electronics with an effective control resolution inside the servo amplifier of  $0.01\mu\text{m}$ . The actual system resolution at the plate is about  $0.055\mu\text{m}$  limited only by the analog command signal from the digital servo controller to the amplifier as well as the phase quadrature position signal from the amplifier which can be adjusted to suit. The bandwidth of the current control loop is 600 Hz while the velocity loop can be tuned to better than 200 Hz. The design target for the position loop is 100 Hz to handle possible microphonic control.

## Cold Test Results

The mechanical tuner performance has been characterized over several cold tests from Oct. 2002 to present. Since the tuner plate is linked to the cryostat by the tuner shaft we had concern that tuner or environment noise would

feedback to the cavity. Low frequency (0-10 Hz) dithering of the tuner produced no significant coupling to the cavity microphonics. Except for a mechanical resonance at 20 Hz there is good response out to at least 100 Hz. Present thinking is that the mechanical resonance is due to a dogleg in the push-rod that is necessary in the test cryostat but can be eliminated in the on-line system.

The tuner on-line performance is measured by altering the cavity frequency by forced variations of the helium pressure with a valve on the vent gas line. In general the pressure variations are more extreme than we expect for the on-line system but they allow us to optimize the PID parameters for the control and tuner loops. Data is taken for a variety of cavity field and coupling strength settings. Results for a high field case are shown in Fig. 3. The bandwidth for the high field case is limited by the maximum power of the test amplifier. The plot gives the pressure change and the associated position drive signal for the tuner as well as the voltage and phase error. Note that the phase error resolution is limited to  $1^\circ$  by the 12 bit ADC. The plots show that the tuner responds accurately to the pressure variation with a resolution better than  $0.1\mu\text{m}$  (0.6 Hz).

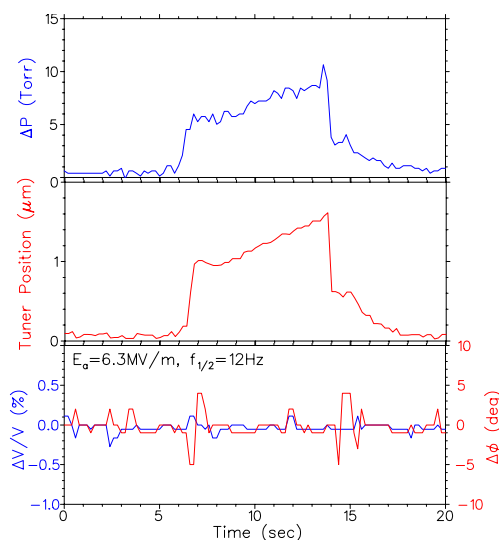

Figure 3: Tuner response to forced helium pressure fluctuation ( $\frac{\Delta f}{\Delta P} = 1\text{Hz/Torr}$ ) and corresponding voltage (blue) and phase (red) errors for high field ( $E_a=6.3$  MV/m) and a bandwidth of  $\pm 12$  Hz.

The dynamic range of the tuner is limited by the motor strength to  $\pm 4$  kHz. A threaded position platform for the spring tensioner is used to provide manual coarse frequency adjustments. A tuning range of 33 KHz has been demonstrated and was limited only by mechanical stops on the platform that will be altered to give the full 40 kHz design range.

## COUPLING LOOP

Original cold tests with a prototype quarter wave cavity were done with an adjustable coupling loop copied from an

INFN-Legnaro design that we identify as Mark I. The loop consists of a brass outer housing, a copper plated stainless steel outer conductor and copper inner conductor. The outer conductor is driven in/out through a rotating mechanical shaft attached to a stepper motor on the cryostat lid via a rack and pinion mechanism on the loop housing. The original in-vacuum rf drive line consisted of a 1 m length of flexible coaxial cable with a 30 cm rigid section of copper coated stainless steel for thermal isolation. The loop was designed to operate at gradients of 3-4 MV/m with a forward power of about 50 W. Early cold tests at higher power showed significant heating of both the drive system and the loop assembly with several Watts of power being deposited in the helium.

### Prototypes and Cold Tests

Cold tests are done by first measuring the static heat loss based on the helium boil-off rate after full thermalization. The cavity is then powered until thermal equilibrium is reached and the new static heat load is measured. The temperature of the loop is monitored by several sensors during power on and power off cycles.

The loop prototypes maintain the Legnaro dimensions and loop adjustment system but the loop materials are altered and LN2 cooling is added. In Mark II the housing is changed to thin walled stainless steel for better thermal isolation and the outer conductor is copper. A copper heat exchange block is fastened to the outer conductor. Copper braid thermally links both the block and current maximum points on the cable to an LN2 cooled copper pipe (Fig. 4). The stainless steel rigid line section is removed and replaced by one continuous flexible cable. With an ini-



Figure 4: The Mark II loop prior to cold test.

tial forward power at the loop of 140 W in fixed gradient mode the temperature of the inner conductor becomes sufficiently high to change the coupling and the forward power grows to 200 W during thermalization. The loop heating causes 4.5 W extra static boil-off. A reduction in heating to 2.5 W is obtained by adding heat shields tied to the LN2 pipe around the rf cable.

The Mark III loop is identical to Mark II but two 1 cm long pieces of Aluminum Nitride (AlN) dielectric are

added to thermally connect the inner and outer conductor of the loop near the heat exchange block to reduce inner conductor heating. In this case the loop heating adds only 1.5 W to the static heat load and the coupling and forward power remain constant at 200 W throughout the test. In addition the improvement in the thermal path reduces the thermalization time from 6 hours to 2 hours.

In the Mark IV prototype (Fig. 5), soon to be tested, the outer conductor and heat exchange block form a solid piece. A cooling channel running through the block allows direct cooling with LN2.

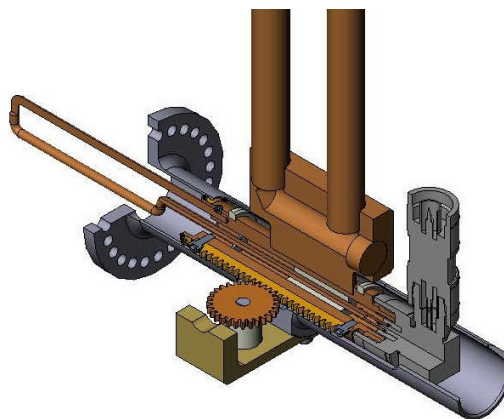

Figure 5: A cut-away rendering of the Mark IV coupling loop.

## CONCLUSION

At 200 W forward power RF heating of the inner conductor in the absence of a good thermal path can lead to expansion of the inner conductor and change in the coupling for fixed gradient. AlN ceramic provides an effective way to divert the heat to the LN2 heat sink. Heating of the cable can be handled by adding a heat shield linked to LN2 to stop radiation to the 4K surfaces. The tuner is a significant advance on mechanical tuners presently used on quarter wave structures due to its high precision (0.3 Hz), and response bandwidth (presently limited to 20 Hz). In addition the convoluted lower tuning plate and robust tuner mechanical design allow cold plastic deformation of the plate reducing the tolerance on cavity geometry necessary during cavity fabrication.

## REFERENCES

- [1] R.E. Laxdal, *et al*, *The ISAC-II Upgrade at TRIUMF: Progress and Developments*, PAC2003.
- [2] J. Delayen, *et al*, *TM<sub>010</sub> Cavities, RF Control, Tuners, Couplers*, RIA Driver Workshop II, Argonne, May 22-24, 2003.
- [3] A. Facco, *et al*, *Mechanical Mode Damping in Superconducting Low-beta Resonators*, Proc. of the Eighth RF Superconductivity Workshop, Abano, 1997.
- [4] K. Fong, *et al*, *RF Control System for ISAC-II Superconducting Cavities*, PAC2003.